



NEW HOLLAND

L150 L160 L170 L175 L185 SUPERBOOM® SKID STEER LOADERS



C175 C185 SUPERBOOM® COMPACT TRACK LOADERS



	L150	L160	L170	L175	L185	C175	C185
ENGINE POWER	38 hp	46 hp	52 hp	60 hp	82 hp	60 hp	82 hp
OPERATING LOAD	612 kg	726 kg	801 kg	907 kg	1134 kg	1429 kg	1652 kg
TRANSPORT WEIGHT	1967 kg	2435 kg	2438 kg	2751 kg	3161 kg	3343 kg	4053 kg

NEW HOLLAND
CONSTRUCTION
BUILT AROUND YOU

C175/C185



NEW HOLLAND SUPER BOOM® DESIGN

- Fast cycle times for high productivity
- Great stability for better operating and manoeuvring
- Long forward dump reach for effective truck loading

COMFORTABLE CONTROLS

- Optional Pilot Controls for easier working operations
- Hand throttle, joysticks location for operators' convenience

L150/160/170/175/185



DELUXE CAB

- All round visibility: no rear frame to block the view, effective cluster and lights lay-out
- Front door design for outstanding front view
- Downward sight lines for better view of the attachment

TIER III ENGINES

-  4-cylinder, turbo engines: high torque and productivity for L185.
- ISM engines: proven reliability for L150, L160, L170, L175
- Tier III certified: environmental care with low fuel consumption and low operating costs

EASY SERVICE AND ACCESSABILITY

- Rear door design for easy service access
- Time - saving maintenance solution
- Long service intervals

L 150/160/170/175

NEW HOLLAND SUPERBOOM®

Reliability & Productivity to face your daily challenge

- **OPTIMUM STABILITY:** long wheelbase, low center of gravity and proper weight distribution keeps the load closer throughout the lift cycle
- **EFFECTIVE COMPACTNESS:** big performance in small places, lower overall height for best manoeuvrability under low overhangs, narrow spaces and around tight corners
- **MAX HINGE PIN CLEARANCE:** more effective loading
- **EXCELLENT LIGHT OF SIGHT:** full visibility to the attachment when loader arms are raised
- **STEEP DUMP ANGLES:** dump completely the bucket even with the stickiest material inside



BEST IN CLASS LIGHTING PACKAGE FOR BETTER NIGHT WORKING

Extended visibility in dust and dark conditions with a lighting package that's superior to the competition. Just compare the extended area of illumination provided by the new Super Boom cab. It gives you a competitive advantage that allows you to work with confidence, and at maximum productivity in fog, dust or at any hour.

FORWARD LIGHTING

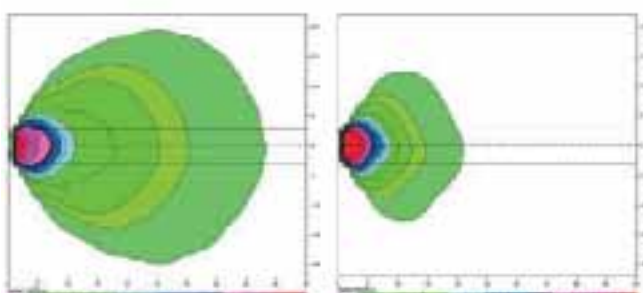

New Holland

Competitor

REARWARD LIGHTING

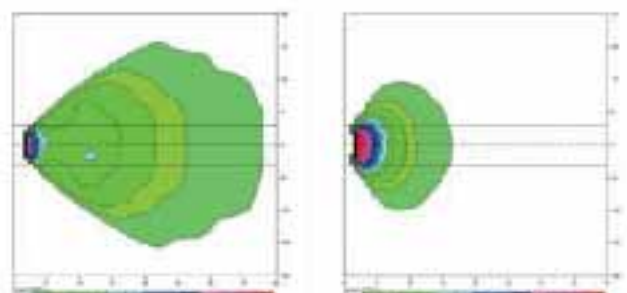

New Holland

Competitor

/185/C175/185



DELUXE CAB

Comfort & Safety in operating

- **LOOKING FORWARD OR REARWARD:** operator's easy visibility is always ensured to manoeuvre on all terrains work site
- **CAB DESIGN MAXIMISING VISIBILITY:**
 - the see-through area on the cab roof provides a clear view to the bucket, even when it is positioned at full height,
 - windshield wiper position for a clearer view in all conditions
 - front lights slim design effectively located at the side of the cab or ROPS expands your view to the front especially to the upper corners, making it easier to position loads overhead and manoeuvre in low-clearance areas
- **FOR YOUR COMFORT AT WORKING:**
 - hand throttle is conveniently located to your right, allowing you to simultaneously drive with the left stick, while adjusting engine speed with your right hand
 - Long, contoured, adjustable armrests provide superior forearm support
 - The ample leg room and foot room add comfort to your operators.A comfortable, countered suspension seat is standard equipment

Expanding your comfort maximize the worksite efficiency

- Deluxe Cab Enclosure is a COMFORTABLE, QUIET and CLEAN ENVIRONMENT for you daily job
- A huge glass door opens a full 90 degrees for easy entry and exit and, when closed, provides SUPERIOR VISIBILITY to all corners and creates an open, uncluttered sense of space
- Heater/defroster kit and optional air conditioning allows you to control the climate in any weather
- LOW NOISE INTERIOR sound level due to full-covering and noise absorbing trim
- The cab sealing provides REDUCED DUST INFILTRATION
- A demolition door is available in lieu of a glass door to rugged working conditions
- Easy to reach, eye-level backlit controls provide the operator with a quick, at-a-glance evaluation of all vital loader functions
- Ample leg room and foot room add comfort to your operators



L150/160/170/175

CONTROL OPTION Comfort & Productivity for your style of control

- **PILOT CONTROL SYSTEM:**
L160 through L185 offer the New Holland pilot control that makes working operations easier and more comfortable.
- **EFFECTIVE JOYSTICKS:**
Instant response with minimum movement, resulting in precise control and less fatigue:
 - The left joysticks controls steering and machine travel (forward and reverse).
 - The right joystick provides full control of the lift arm and attachment tilt. Press front or back to raise and lower the lift arm. Move the joystick right and left to dump or curl the bucket or attachment.



TIER 3 ENGINE Respectful Power

- The NEW HOLLAND engine guarantees high power respecting
 - Your personal needs LOW NOISE, REDUCED VIBRATIONS
 - Your economic requirements for LOW CONSUMPTION
 - Thee environmental needs of LOW EXHAUST EMISSIONS
- Additional features are: excellent RELIABILITY and EFFICIENCY



/185/C175/185



EASY ACCESS & SERVICEABILITY: designed to give effectiveness, confidence and reliability



- The rear door provides easy service access for periodic maintenance and daily check points: engine oil, fuel fill, hydraulic oil, coolant and radiator points may be accessed without tools.
- The service door latch is located on the outside of the door where it can be secured with one lock, providing security to the engine compartment and major components.
- The radiator can be cleaned from both sides..
- The entire cab and boom assembly lift forward and up for full access to the engine or transmission.
- The operator is able to engage and disengage the boom lock from inside the cab.

C175/185 UNDERCARRIAGE

LESS COMPONENTS + FEWER PARTS = LESS OPERATING COST!

Rigide undercarriage with fewer moving parts reduces maintenance costs compared to track suspension system

New Holland compact track loaders combine the superior reach and lift capacity of the exclusive Super Boom load arm design along with the advantages of wide, durable tracks:

- Improved traction in loose, sandy, or muddy conditions to push heavier loads
- Faster travel speeds-even over rough ground
- Low ground pressure gives you maximum flotation and minimum soil disturbance

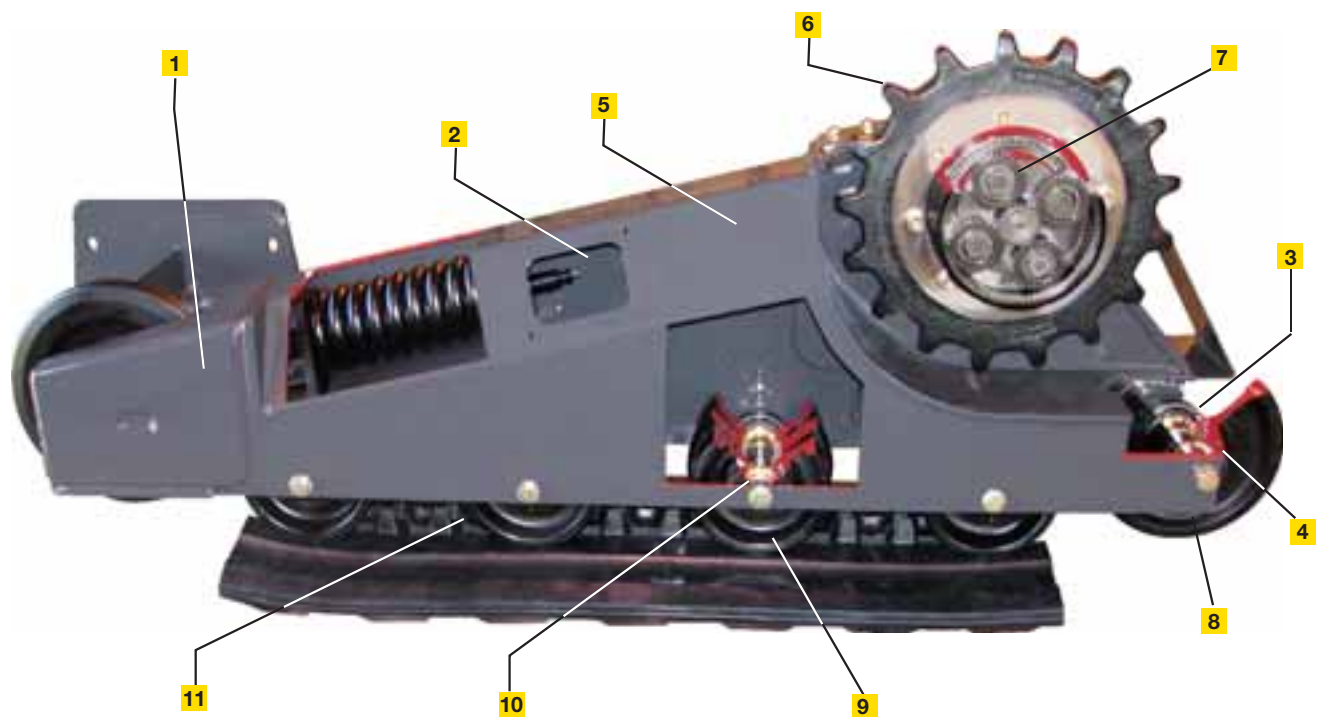

LOW MAINTENANCE:

- 1 Rigid Frame** with fewer moving parts means reduced cost of ownership compared to suspension track systems.
- 2 Easy Track Adjustment** using a standard wrench and grease gun makes for quick and easy service.
- 3 Sealed and Oil Lubricated Rollers & Idlers** for extended life of undercarriage.
- 4 Large Brass Bushings** distribute load better than bearings and offer resilience and longevity.

EASY TRACK CLEAN- OUT:

- 5 Tapered Track Frame** sheds mud and any other material to keep the track system clean.
- 6 Elevated Drive Sprocket** increases component life by keeping the motor assembly out of material and moisture.

SMART TECHNOLOGY:

- 7 Standard Two-Speed** allows for greater speed variations to perform a wide variety of jobs.
- 8 Single Flange Front and Rear Idlers** help prevent e-tracking on inclines.
- 9 Crawler-Style Rollers** help prevent de-tracking on inclines by using a larger inner diameter flange positioned between the track tabs.
- 10 New Holland Crawler Technology** incorporates metal face seals into rollers and idlers.
- 11 Steel Embedded Track Cables and Cross Bars** resist stretching while transferring the power of the drive train through the track and to the ground.

Model C175 features a 320 mm track. Models C185 are available with two track options: 400 mm: excellent flotation with additional pushing power or 450 mm: maximum flotation for sensitive turf

L150/160/170/175/185

DIMENSIONS

C175/185

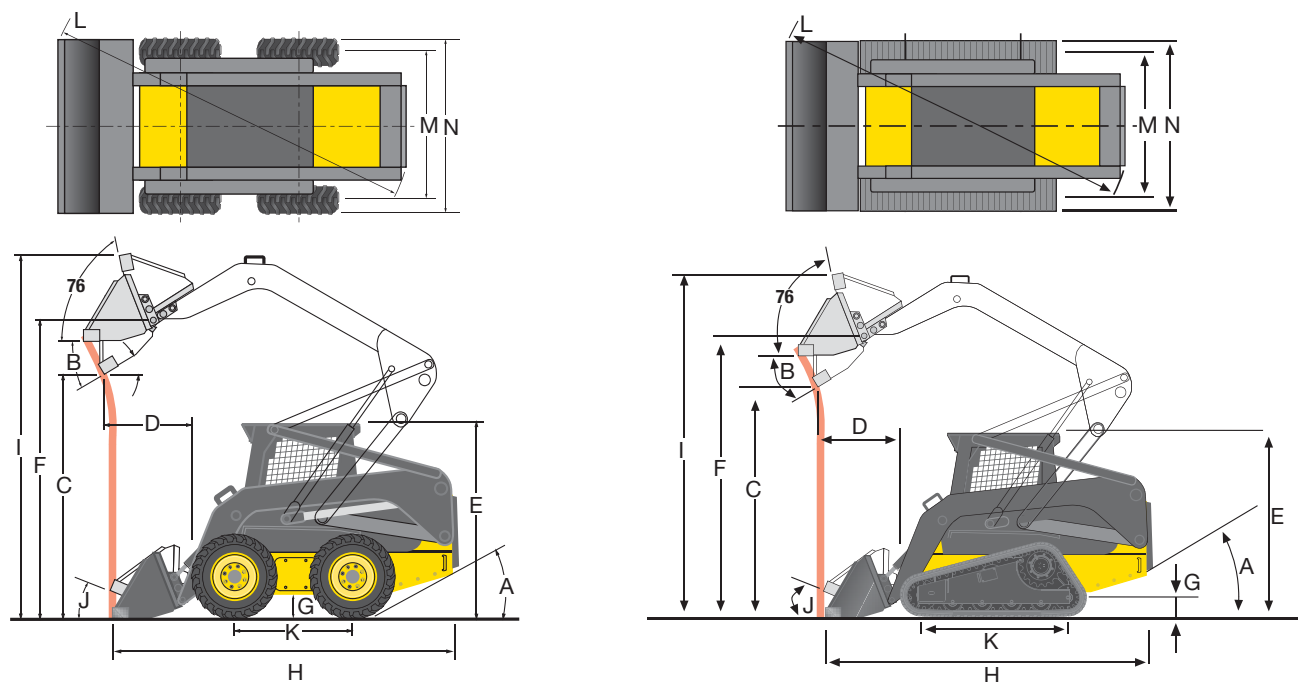

	A (°)	B (°)	C mm	D mm	E mm	F mm	G mm	H mm	I mm	J (°)	K mm	L mm	M mm	N mm
L150	28	45	2341	505	1883	2940	215	3081	3599	35	945	3291	1217	1524
L160	28	44	2371	709	1935	2996	219	3240	3652	35	1080	3519	1370	1624
L170	28	44	2371	709	1935	2996	219	3240	3652	35	1080	3519	1370	1624
L175	27	43	2428	703	1975	3070	241	3293	3742	36	1080	3520	1488	1793
L185	26	45	2569	840	1999	3219	226	3587	3861	37	1219	3795	1486	1810
C175	28	43	2410	780	1920	3030	200	3290	3700	37	1140	3970	1490	1810
C185	32	45	2550	830	1980	3170	260	3550	3840	37	1640	4060	1650	2090*

* with 450 mm tracks





L150-L160 - Equipped with 1520 mm dirt and foundry bucket and 10.00 x 16.5 tires
 L170 - Equipped with 1672 mm dirt and foundry bucket and 10.00 x 16.5 tires

L175-L185 - Equipped with 1830 mm dirt and foundry bucket and 12.00 x 16.5 tires
 C175-C185 - Equipped with 1830 mm dirt and foundry bucket and 12.00 x 16.5 tires



150/160/170/175

SPECIFICATIONS

 PERFORMANCE	L150	L160	L170	L175	L185	C175	C185
Operating load - 50% of tipping load	612	726	801	907	1134	1429	1652
SAE operating load (kg).....	429	508	560	635	794	1000	1157
Tipping load (kg) without weights per SAE J-732	1225	1451	1601	1814	2268	2858	3305
Max low/high speed (Km/h)	-/11.8	-/11.8	-/11.8	9.5/16.1	11.1/18.2	9.0/12.0	8.7/13.8
Total boom-cycle time (sec)	9.6	9.7	8.2	9	8.7	9.0	8.7
Raising time (sec)	3.1	3.0	2.7	3.1	2.8	3.1	2.8
Dumping time (sec)	1.6	2.0	1.7	2.3	1.8	2.3	1.8
Lowering time (sec)	3.5	3.0	2.3	2.1	2.5	2.1	2.5
Retract time (sec)	1.4	1.7	1.5	1.5	1.6	1.5	1.6
Transport weight (kg)	1967	2435	2438	2751	3161	3343	4053
Operating Weight (SAE).....	2042	2510	2513	2826	3236	3418	4128
 ENGINE TIER 3A							
Engine power gross (hp)	38	46	52	60	82	60	82
Engine power SAE net (hp)	36	44	50	56	77	56	77
Peak torque	9Nm@1900rpm	7Nm@1700rpm	3Nm@1700rpm	3Nm@1700rpm	0Nm@1400rpm	3Nm@1700rpm	0Nm@1400rpm
Torque rise	15%	20%	20%	20%	32%	20%	32%
Make/Model.....	ISM/N843H	ISM/N844	ISM/N844T	ISM/N844LT	FPT/F5C E5454	ISM/N844LT	FPT/FSCE5454
Displacement (l).....	1.5	2.0	2.0	2.2	3.2	2.2	3.2
Cylinders (n°).....	3	4	4	4	4	4	4
Air cleaner	Dual stage, dry element filter						
Fuel.....	Diesel	Diesel	Diesel	Diesel	Diesel	Diesel	Diesel
 CAPACITIES							
Cooling system (L).....	9.3	10.2	10.2	11.4	11.4	11.4	11.4
Engine crankcase (w/filter) (L)	5.5	6.5	6.5	8.0	8.5	8.5	8.5
Fuel tank (L).....	33.1	54.5	54.5	61.7	86.7	61.7	86.7
Hydraulic oil system (L).....	18.9	32.6	32.6	32.6	56.8	32.6	56.8
 HYDRAULIC SYSTEM							
Standard auxiliary hydraulics (gear type)(L/minute).....	44	57	65	65	79	65	79
High flow hydraulics (if equipped)	NA	NA	97	97	136	97	136
Oil reservoir (l).....	5.7	14.8	14.8	14.8	18.9	14.8	18.9
Relief pressure setting (bar)	172	172	172	172	210	172	210
 ELECTRICAL SYSTEM							
Alternator	40 A	40 A	40 A	55 A	95 A	55 A	95 A
Battery (maintenance free).....	12 V 650 CCA	12 V 650 CCA	12 V 650 CCA	12 V 650 CCA	12 V 1125 CCA	12 V 650 CCA	12 V 1125 CCA
System protection	30 A circuit breaker						

INSTRUMENTS: Hour meter, voltage alarm, hydraulic oil temperature light and alarm, coolant temperature light and alarm, fuel gauge, transmission charge, pressure light and alarm, engine oil pressure light and alarm, seat belt light, engine malfunction light and alarm, transmission filter restriction light and alarm, parking brake reminder light.

/185/C175/185

ATTACHMENTS OFFERING



Beyond a complete range of buckets (heavy duty, low profile, Utility, Light Material and 4-in1 multipurpose buckets) New Holland skid steers do a lot more than lift and load thanks to the following wide range of attachments thoroughly tested and approved by our engineering:

CEMENT MIXER

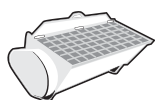

For loading of aggregates and cement mixing

Width	Capacity	Weight	Hydraulics	
1000 mm	0.35 m ³	380 Kg	Std	from L185/C185
1500 mm	0.30 m ³	300 Kg	Std	from L160/C175
1250 mm	0.20 m ³	280 Kg	Std	L150

COLD PLANER

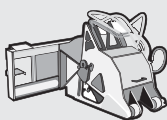

- For resetting damaged surfaces
- For preparing of medium trenches
- For preparing of medium trenches
- For patch repairs, and finish planning

Width	Depth	Weight	Hydraulics	
1000 mm	0-130 mm	450 Kg	Std	from L185/C185
600 mm	0-170 mm	750 Kg	Hi-flow	from L160/C185
450 mm	0-150 mm	900 Kg	Hi-flow	from L160/C175
110 mm	0-110 mm	1070 Kg	Hi-flow	L150

BROOM BUCKET



Ideal for clearing yards, roads, footpaths...

Width	Capacity	Max width	Weight	Hydraulics	
1850 mm	0.43 m ³	2095 mm	420 Kg	Std	from L175/C175
1080 mm	0.38 m ³	1925 mm	336 Kg	Std	from L160/C170
1525 mm	0.35 m ³	1770 mm	300 Kg	Std	L150

SIDE TIP BUCKET

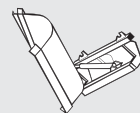

Tip to the side of the machine to fill trenches, feed troughs... Available for right side tipping or left side tipping

Width	Capacity	Weight	Hydraulics	
1850 mm	0.55 m ³	250 Kg	Std	from L175/C175
1680 mm	0.50 m ³	245 Kg	Std	from L160/C170
1525 mm	0.40 m ³	230 Kg	Std	L150

HIGH TIP BUCKET



Increases the dump height of the machine by 80 cm to 120 cm

Width	Capacity	Dump height	Weight	Hydraulics	
1850 mm	0.55 m ³	3460 mm	352 Kg	Std	from L175/C175
1680 mm	0.41 m ³	3640 mm	285 Kg	Std	from L160/C170
1525 mm	0.39 m ³	3640 mm	264 Kg	Std	L150

GRAPPLE BUCKET

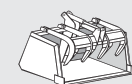

Light and moderate duty applications in farms, refuse stations...

Width	Capacity	Weight	Hydraulics	
1680 mm	0.75 m ³	324 Kg	Std	L160/L170
1525 mm	0.60 m ³	300 Kg	Std	L150

INDUSTRIAL GRAPPLE



Heavy duty twin cylinders attachment suitable for foundry scrap metal, waster paper and recycling

Width	Capacity	Weight	Hydraulics	
1830 mm	0.77 m ³	350 Kg	Std	from L175/C175
1680 mm	0.75 m ³	350 Kg	Std	L160/C170
1525 mm	0.60 m ³	350 Kg	Std	L150

L150/160/170/175/185 C175/185 ATTACHMENTS OFFERING

SNOW DOZER BLADE

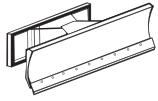

+/- 30° angle blade
Manual or hydraulic

Width
2135 mm
1980 mm

Weight
288 Kg
285 Kg

Hydraulics
-/Std from L175/C175
-/Std All models

FARM FORK WITH GRAPPLE

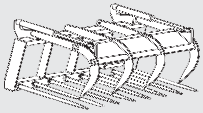

For bale and silage
handling and many farms
activities...

Width
1850 mm
1680 mm
1525 mm

**Capacity
(open/close)**
1.01/0.66 m³
0.92/0.62 m³
0.85/0.55 m³

Weight
310 Kg
260 Kg
250 Kg

Hydraulics
Std from L175/C175
Std L160/C170
Std L150

PALLET FORKS

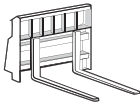

Load of each fork at 500
mm: 1000 Kg
Side shifting available

Lenght
1400 mm
1248 mm
1996 mm

Weight
194 Kg
144 Kg
126 Kg

All models
All models
All models

FARM FORK

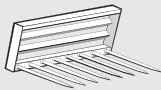

For general farm
yard applications

Width
1850 mm
1680 mm
1525 mm

Weight
185 Kg
170 Kg
153 Kg

from L175/C175
L160/L170
L150

BALE SPIKE

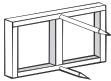

For handling round bales

Width
1220 mm

Weight
55 Kg

All models

BACKHOE ARM

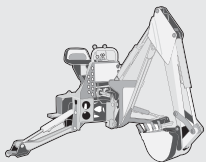

Side shifting
available

Depth
3400 mm
3100 mm
2850 mm

Weight
750 Kg
720 Kg
710 Kg

Hydraulics
Std L185/C185
Std From L160/C175
Std L150

AUGERS



A complete range of augers from 100 to 900 mm diameter is available for each application: Installation of telegraph poles, electricity pylons, signposts, pillars, tree and shrub planting.
For more details consult your dealer.

AT YOUR OWN DEALERSHIP

The information contained in this brochure is intended to be a general nature only. The NEW HOLLAND KOBELCO CONSTRUCTION MACHINERY S.p.A. company may at any time and from time to time, for technical or other necessary reasons, modify any of the details or specifications of the product described in this brochure. Illustrations do not necessarily show products in standard conditions. The dimensions, weights and capacities shown herein, as well as any conversion data used, are approximate only and are subject to variations within normal manufacturing techniques.

Published by NEW HOLLAND KOBELCO CONSTRUCTION MACHINERY S.p.A.
Printed in Italy - LEADER Firenze - Cod. 30 612GB - Printed 04/10

Printed on recycled paper
CoC-FSC 000010 CQ Mixed sources



ELEMENTAL
CHLORINE
FREE
GUARANTEED



BUILT AROUND YOU

www.newholland.com